



# SimplyShade

## **Luna**

*Umbrella Light with **Bluetooth**® Speaker*

SS-LUNA

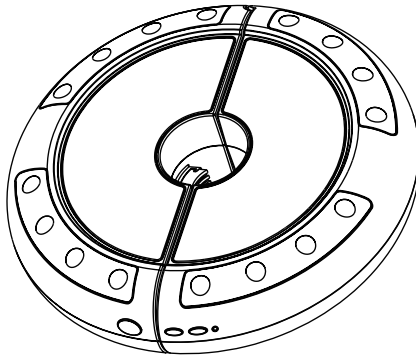

# Instruction Manual

Thank you for purchasing SimplyShade's Luna Umbrella Light.

Please remove all contents from the package, inspect and review checklist.  
CAUTION: To reduce personal injury and damage to your umbrella light, read and follow the instruction manual.

## CHECKLIST

- A - (1) Luna
- B - (1) Power Supply\*

*\*Note: Use only the Power Supply included with Luna. See page 6 for Safety Precautions. ⚠*

A -

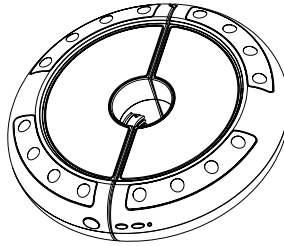

B -

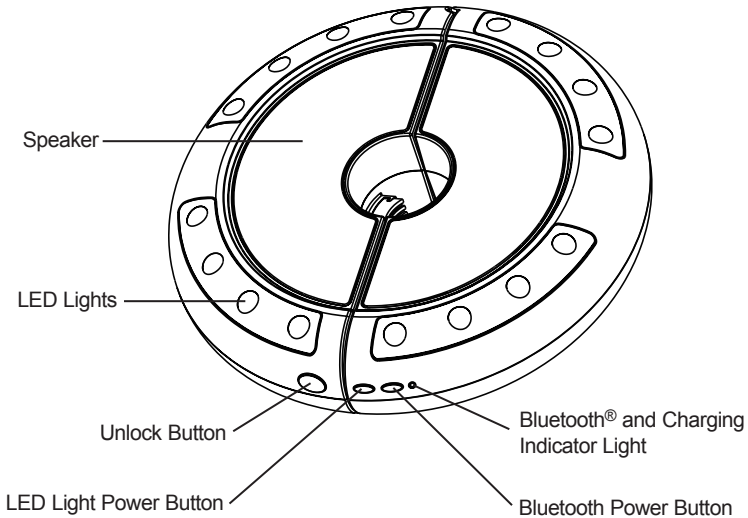

Back View

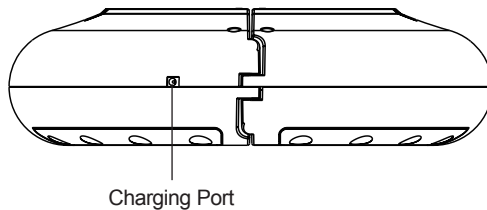

## STEP 1 Charging

- Connect the power supply to the Luna charging port, then plug the other end into any 110V power source. Charge Luna for 2-4 hours. The Luna is fully charged when the Bluetooth indicator light turns off.

### Note:

- Charge Luna in dry area to keep from damaging.
- We recommend fully charging Luna before you store for extended periods of time.
- When the Luna battery is low, you will hear an indicator tone notifying you to charge the Luna.

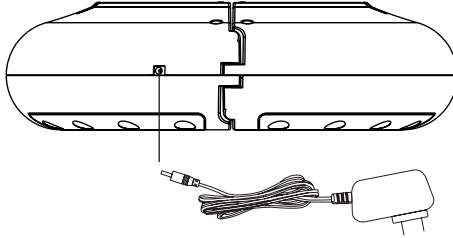

## STEP 2 Pairing Bluetooth Device

- To turn on Bluetooth, locate the Bluetooth power button on the Luna. Press and hold Bluetooth power button for 3 seconds until you hear a prompt sound. The Bluetooth indicator light will blink blue when in pairing mode.
- From your music device, turn on Bluetooth and switch your device to discovery mode. Select "LUNA" from your device options. You will hear a set tone and the Bluetooth light will become solid blue once the Luna and your music device are paired successfully.
- Use controls on music device to select songs from playlists and adjust volume.

### Note:

- Sound quality will lessen or music will stop playing when music device is approximately 30 feet away from Luna.

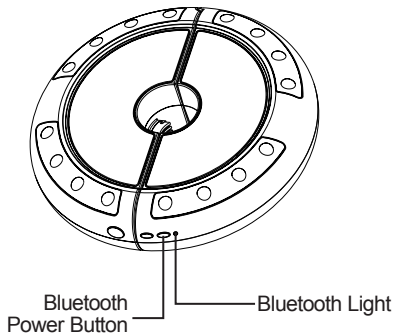

### STEP 3 Unpairing Bluetooth Device

- Only 1 music device can be connected at a time.
- To pair another device, first unpair the current device by disconnecting Bluetooth on device, or pressing and holding the Bluetooth power button for 2 seconds. You will hear a tone when the current music device unpairs and the Bluetooth light will begin blinking blue again.

**Note:**

- If you hold Bluetooth power button for 4 seconds, the device will shut off.

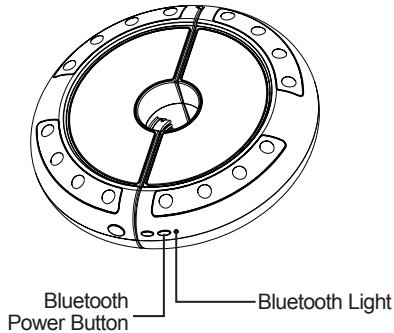

### STEP 4 Turning Off Device

- To turn off Luna, press and hold Bluetooth power button for 4 seconds. You will hear a descending tone and the Bluetooth Indicator light will turn off.

**Note:**

- Luna will turn off automatically when Bluetooth is in pairing mode, or inactive for more than 15 minutes.
- When your music device is disconnected, you will hear a prompt sound from Luna.

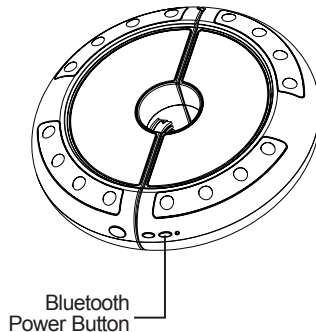

## STEP 5 LED Lights

- To turn on and off LED lights, press the LED light power button.

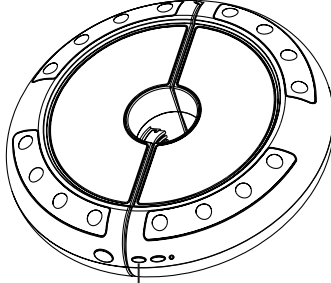

LED Light Power Button

## STEP 6 Attaching Luna to Umbrella

- The Luna can be attached to umbrella center poles up to 2" and cantilever umbrella light adapters.
- Open Luna by holding the device firmly with one hand and then press "unlock" button with the other hand to release the clamp lock.
- Open up the Luna light and clasp around the mid pole or light adapter. Snap to close.

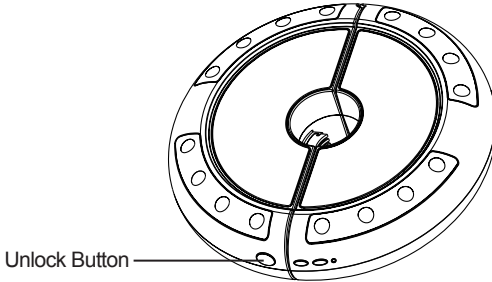

### Center Pole Application

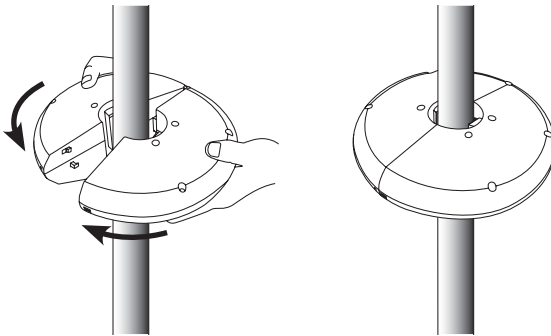

### Cantilever Application

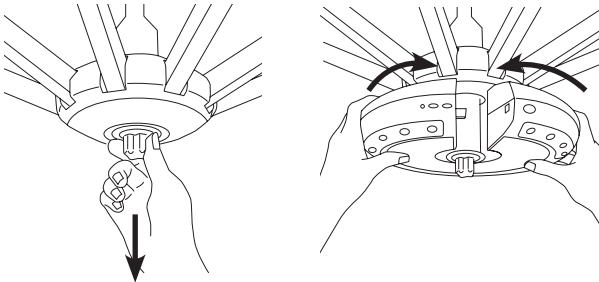

Pull down light adapter

## SAFETY PRECAUTIONS:

- Position Luna in a location that will protect it from direct sunlight and moisture.
- Do not overcharge the battery. Unplug the power supply when the indicator light turns off. Over charging may cause the battery to become hot, rupture or ignite. If you see any heat deformation or leakage, properly dispose of the device.
- If unit is exposed to light moisture, allow unit to air dry for a minimum of 24 hours before reuse.
- Power supply must be used indoors only. It is neither designed nor tested for use outdoors.

**WARNING:** *The Luna umbrella light is not waterproof.* If Luna is immersed in water or exposed to heavy rain the unit will be damaged and void the 1 year warranty.

**NOTE:** We recommend fully charging Luna before you store for extended periods of time.

### Power Supply:

- Never use a third party battery or power supply. Doing so may increase risk of fire or explosion. Contact your local authorized dealer for a replacement power supply.
- During prolonged use, it is normal for the power supply to be warm to the touch. When using power supply, avoid direct sunlight and exposure to moisture.
- Do not attempt to charge the Luna in inclement weather (rain, snow) so as to prevent damage to the electrical components.

#### Power Supply Information

Input voltage: 100-240Vac 50/60Hz

Output: 9VDC 1.2A

5' Cord

### **WARRANTY:**

The manufacturer warrants that this umbrella, when subject to normal and proper use, will be free from manufacturing defects for a period of one year from the original date of purchase. Should any defect occur during the specified time period, the manufacturer will repair, replace, or provide replacement parts, at its own option. Warranty is not transferable.

We will not warrant any claim coverage unless both the original sales receipt and request form are sent to us. Any items that are returned for warranty or non warranty purposes must be issued a Return Authorization Number. Only upon issuance of an RA # and inspection

by our QC department will credit or replacement of umbrella be issued. It is the customer's responsibility to pay the freight on return products or replacement parts. ALL RETURNED ITEMS MUST INCLUDE THE RA# CLEARLY WRITTEN ON THE RETURN PACKAGE or package will be refused by our warehouse personnel.

NOTE: Damages and failure caused by improper use due to neglect of reasonable and necessary care are not covered by this warranty.

Additionally, acts of nature (including but not limited to wind, hurricanes, tornadoes, and storms) are not covered by this warranty.



The Bluetooth® word mark and logos are registered trademarks owned by Bluetooth SIG, Inc. and any use of such marks by SimplyShade is under license. Other trademarks and trade names are those of their respective owners.



[www.simplyshade.com](http://www.simplyshade.com)